

Bigbelly® High Capacity Compactor

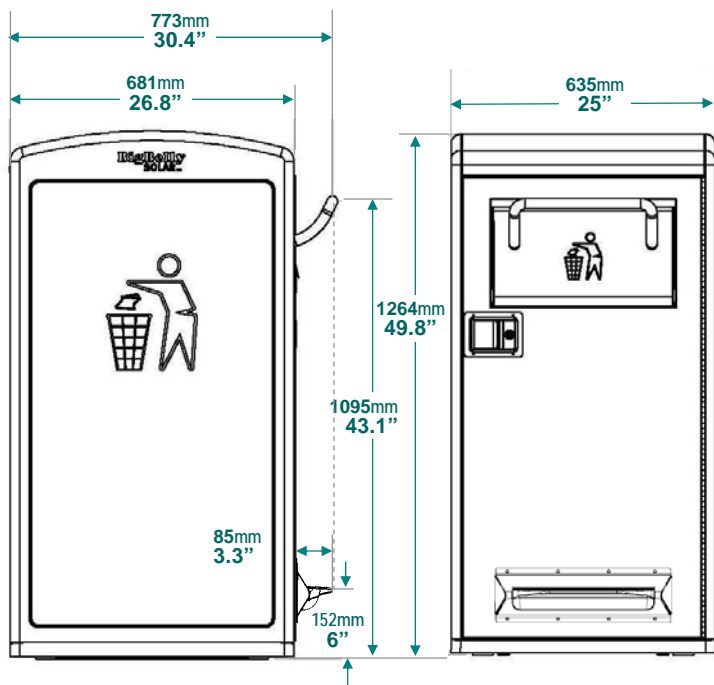

**Configurations: Mixed waste or single-stream recycling
(with appropriate markings)
Above example shown with Foot Pedal.**

Materials

RoHS compliant

Galvanized sheet metal steel interior and exterior construction

Heavy duty plastic side panels for dent and scratch resistance (recycled content)

Interior Bin: Single bin is leak proof made out of low density polyethylene plastic

Power & Electronics

Polycrystalline silicon cell PV module (22 watts).
(40 watts HE [high energy] upgrade available).

PV panel protected by polycarbonate bubble

Spill-proof, sealed maintenance-free battery

Self-powered unit requires no wiring

Technical Specifications (BB5)

Overall Machine Dimensions

Height: 49.8" (1264mm)

Width: 25" (635mm)

Depth: 26.8" (681mm)

Handle Height (ADA Compliant): 43.1" (1095mm)

Weight: 270 lbs (122 kg); Shipping weight: 300 lbs (136.08kg)

Hopper Opening: 6" x 17" (152mm x 432mm)

Bin Volume: 33 gallons (125L) compacted trash; approximately 150 gallons (568L) uncompacted trash

Compactor Features

Compaction: Up to 5-to-1 compaction ratio

Fully automated, microprocessor controlled system senses fullness and machine status

3-color LED status lamps indicate compacted trash level, machine status and error codes

GPRS or CDMA wireless data link for remote monitoring and management

GPS assisted location service

Safety Features

CE approved

Fully interlocked access doors protect users and service personnel

Locked front trash removal door. (Locked rear door option available)

Separately keyed service access

Fault-tolerant design for hopper insertion door prevents access to compaction area

Durability

Weather resistant, UV stabilized polyester powder-coat finish on all exterior parts

Electronic components temperature range of -40°F to +185°F
(-40°C to +85°C)

Fully weatherized, but in the event of a flood, Bigbelly can withstand:

- Up to 20" (508mm) of water without harming the electronics
- Up to 36" (915mm) of water with only minor damage to electronics

Bigbelly Solar, Inc.
150 A Street – Suite 103
Needham, MA 02494 USA



Sales@Bigbelly.com
Bigbelly.com

Toll-free: +1 888.820.0300
International: +1 781.444.6002
FAX: +1 781.444.5651

Station Dimensions

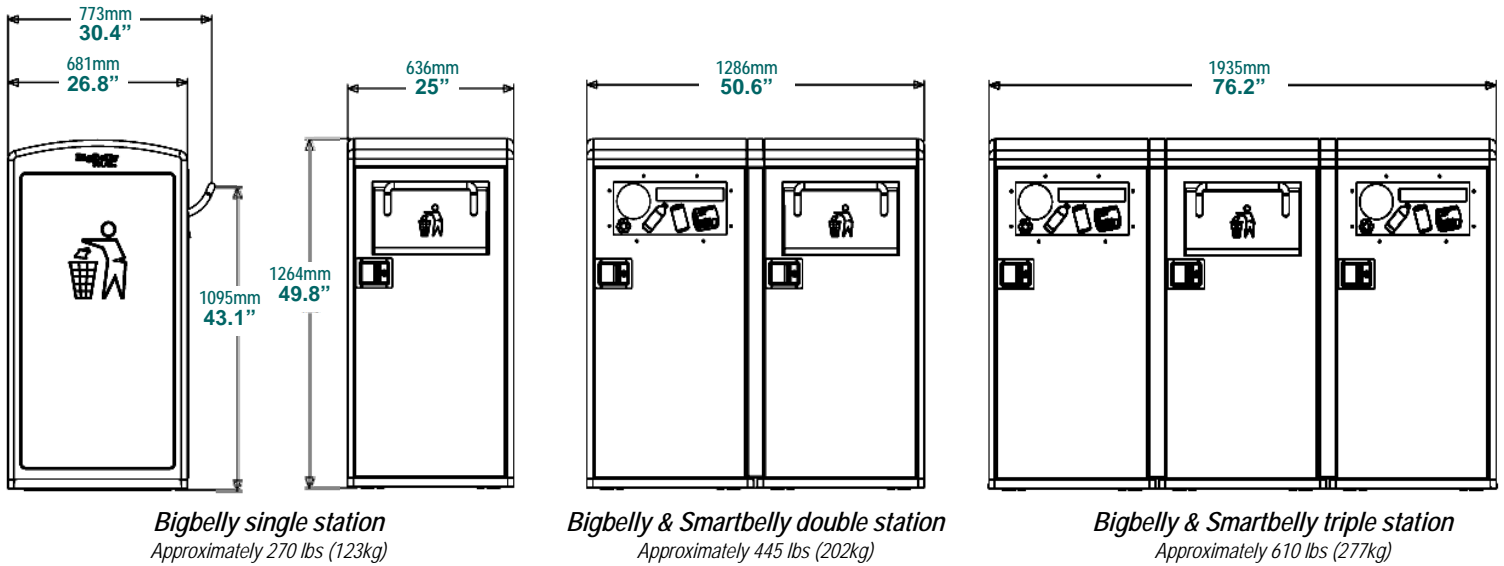

Overall Dimensions	Bigbelly® High Capacity	Smartbelly® Standard Capacity	Smartbelly® Companion
Height	49.8" (1264mm)	49.8" (1264mm)	49.8" (1264mm)
Width	25" (635mm)	25" (635mm)	25" (635mm)
Depth	26.8" (681mm)	26.8" (681mm)	26.8" (681mm)
Handle Height	43.1" (1095mm)	-	-
Weight	270 lb (122kg)	175 lb (80kg)	164 lb (75kg)
Shipping Weight	300 lb (136kg)	205 lb (93kg)	205 lb (93kg)
System Voltage	12V	12V	-
Insertion Opening (see below)	6" x 17" (15.2cm x 43.2cm)	Can be configured for multiple recycling or waste streams.	Can be configured for multiple recycling or waste streams.
Bin Volume	33 gallons (125L) compacted; 150 gallons uncompactd	50 gallons (189L)	50 gallons (189L)
Other			
Liner Bags	<p>Custom Bigbelly Liner Bags (#BBS-CB4647 or #BBS-RCB4647) are available for purchase. Contact WasteZero at 800.866.3954 or www.WasteZero.com/Bigbelly.</p> <p>The black or clear bags are 47"H x 46"W (120cm x 117cm) and 2.5mil (64µ) thick.</p>	<p>Custom Smartbelly Liner Bags (#BBS-RB4255) are available for purchase. Contact WasteZero at 800.866.3954 or www.WasteZero.com/Bigbelly.</p> <p>The clear bags are 55"H x 42.5"W (140cm x 108cm) and 1.25mil (32µ) thick.</p>	<p>Custom Smartbelly Liner Bags (#BBS-RB4255) are available for purchase. Contact WasteZero at 800.866.3954 or www.WasteZero.com/Bigbelly.</p> <p>The clear bags are 55"H x 42.5"W (140cm x 108cm) and 1.25mil (32µ) thick.</p>

Bigbelly Hoppers



Smartbelly Flaps



Smartbelly Faceplates



PLEASE NOTE: Green hoppers, faceplates or flaps require additional 6 weeks to process.